

Inspection dimensions for gaps beside pedal:

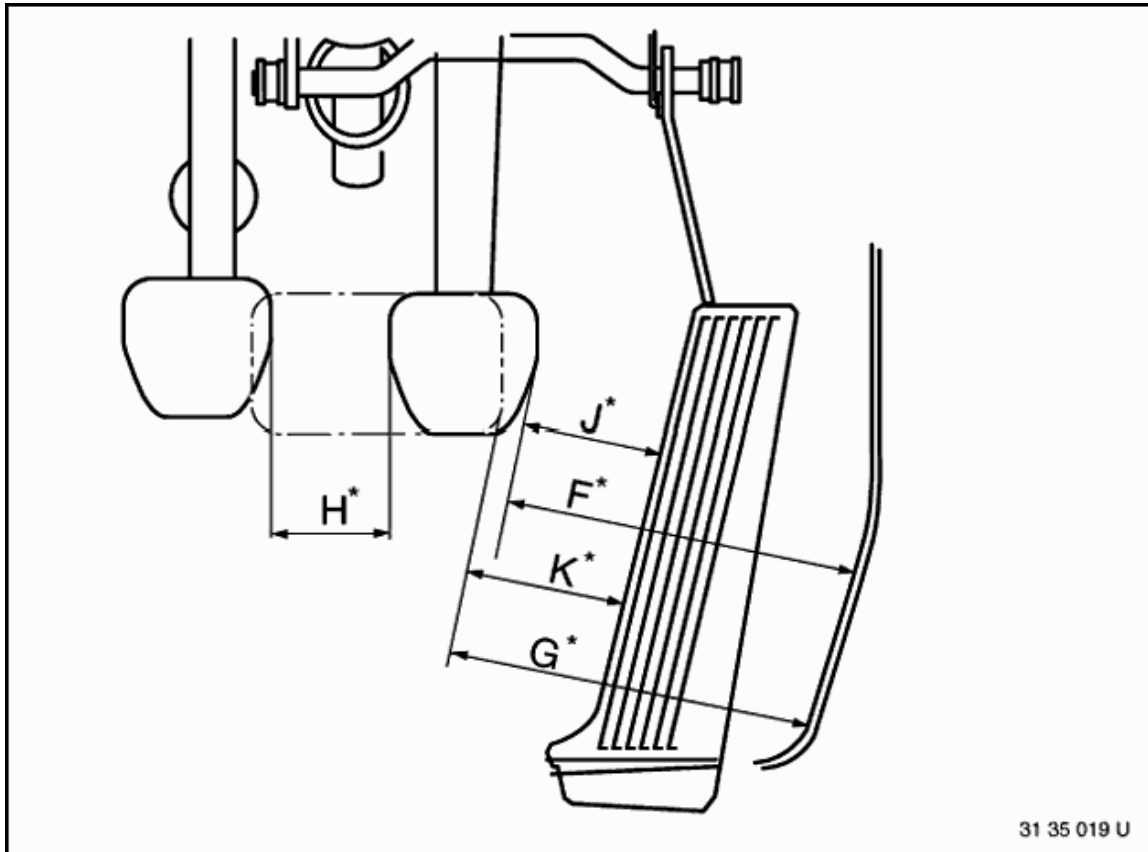

Dimension H, J, K, F, G,
refer to Technical Data.

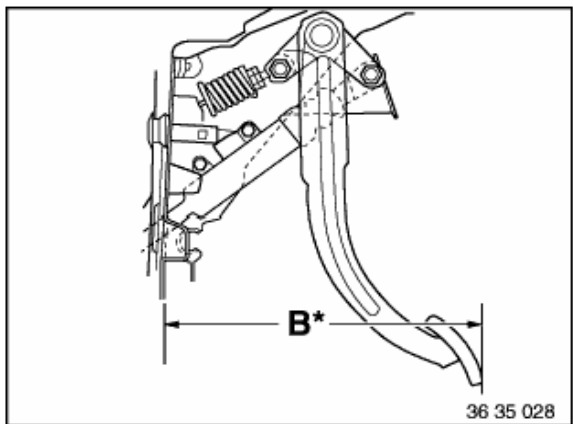

Inspection dimension (B) from underside of pedal to face wall for:
Clutch pedal (dimension B),
refer to Technical Data.
Brake pedal (dimension A),
refer to Technical Data.

Inspection dimension (C) for accelerator pedal,
refer to Technical Data.

